

PKG Start Date:

REV Date: Jan 09, 03

APPROVED

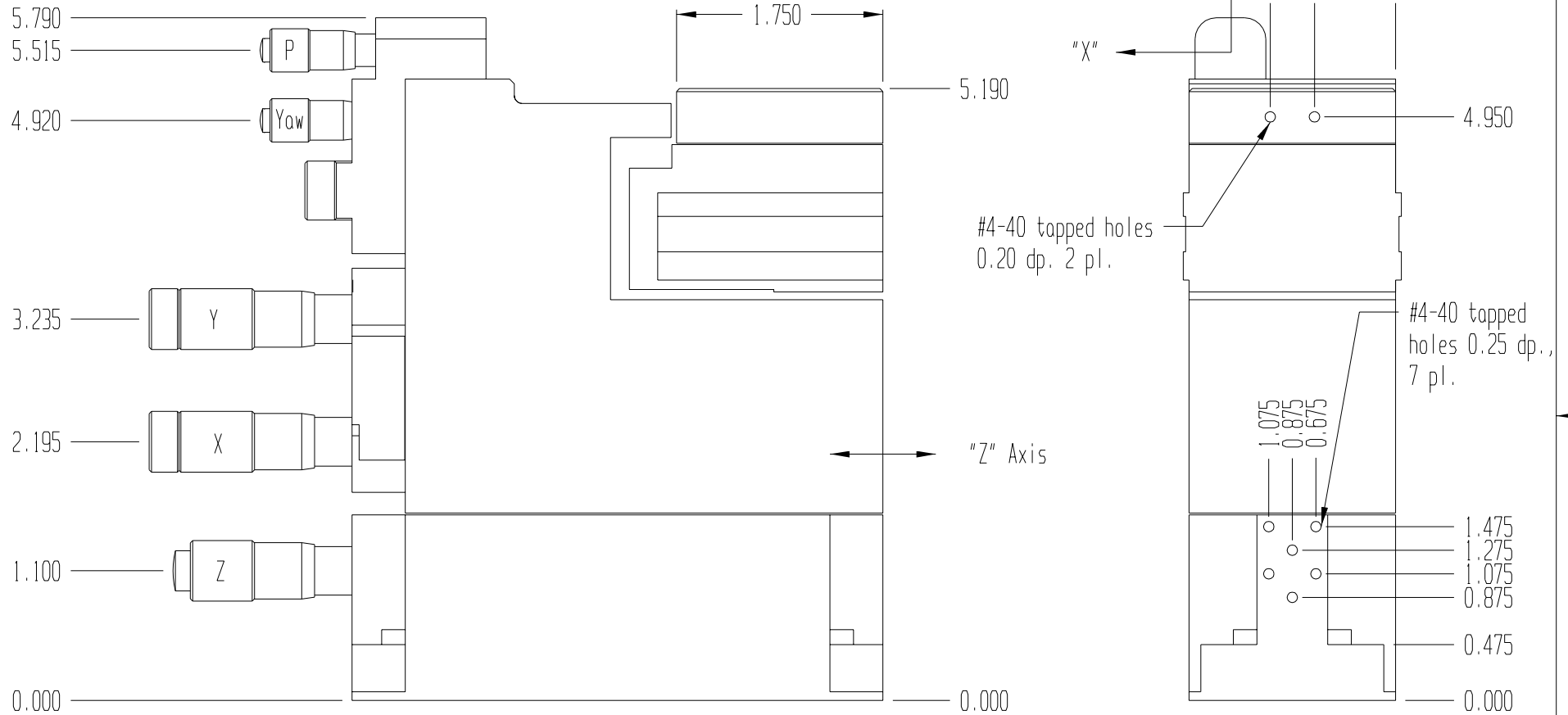

NOTE: Stage is shown in mid-position of travel  
 Z-Axis travel: +/- 0.250" (6.35mm)  
 X&Y Axis travel: +/- 0.040" (1.02mm) (coarse adjustment)  
 +/- 0.010" (250µm) (fine adjustment)  
 Yaw & Pitch: +/- 1.5° each axis

LUMINDS INDUSTRIES LTD

15000 XYZYP Positioner (manual) - Front & End Outline

Material:	
Finish:	Tolerance

SIZE A	VIEW	DWG NO.	15000-01	REV
SCALE 0.75	FILE	15000.prt	SHEET 1/3	

DESCRIPTION	REV Date: Jan 09, 03	APPROVED
-------------	----------------------	----------

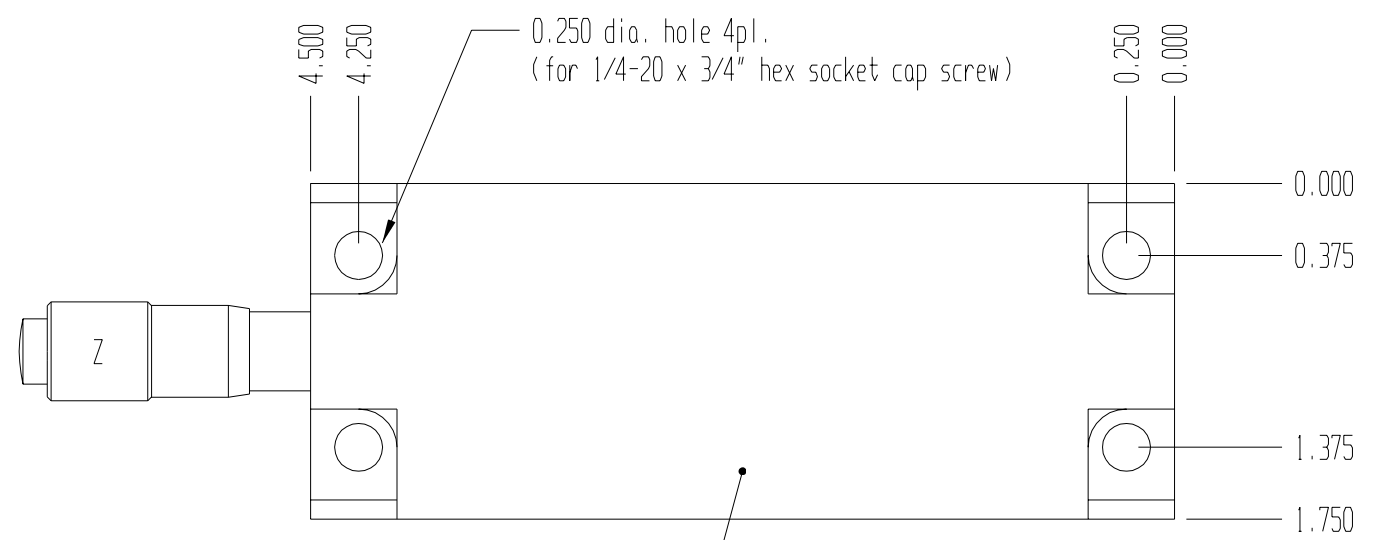
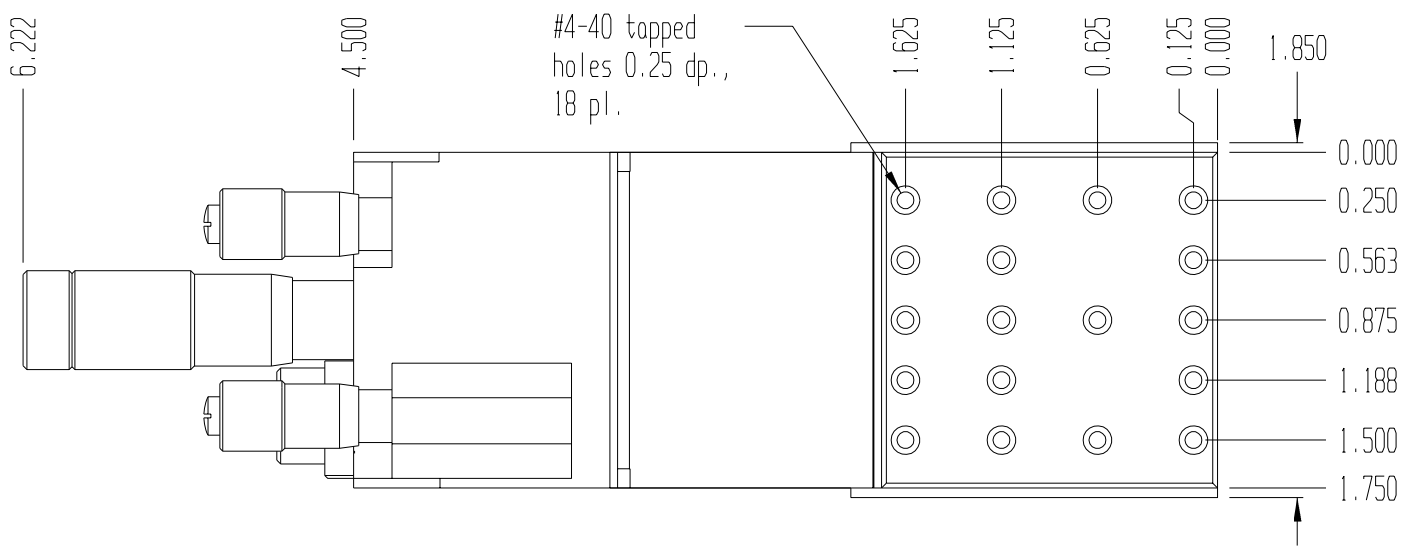

Bottom outline - Z Axis stage only

LUMINOS INDUSTRIES LTD

15000 XYZYP Positioner (manual)

Outline Top & Bottom (Z-Axis stage only)

Material:		SIZE A	VIEW	DWG NO.	15000-01	REV A
Finish:	Tolerance	SCALE 1	FILE	I5000.prt	SHEET 2/3	

PKG Start Date:

REV Date: Jan 09, 03

APPROVED

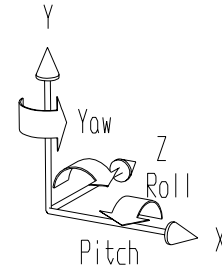
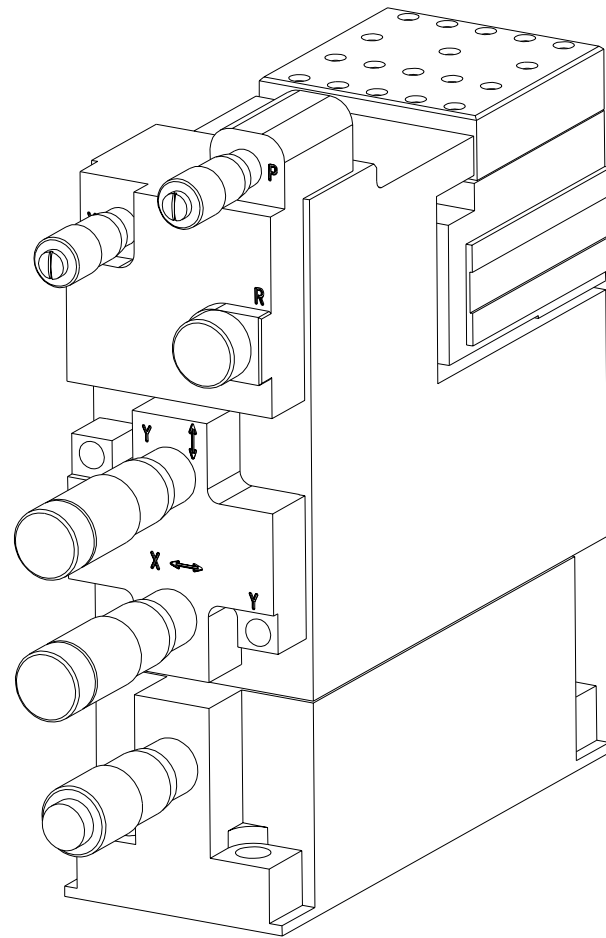

LUMINDS INDUSTRIES LTD

I5000 XYZYP Positioner (manual) - Perspective View

Material:  
Finish: Tolerance

SIZE A	VIEW	DWG NO.	I5000-01	REV
SCALE 0.75	FILE	I5000.prt	SHEET 3/3	

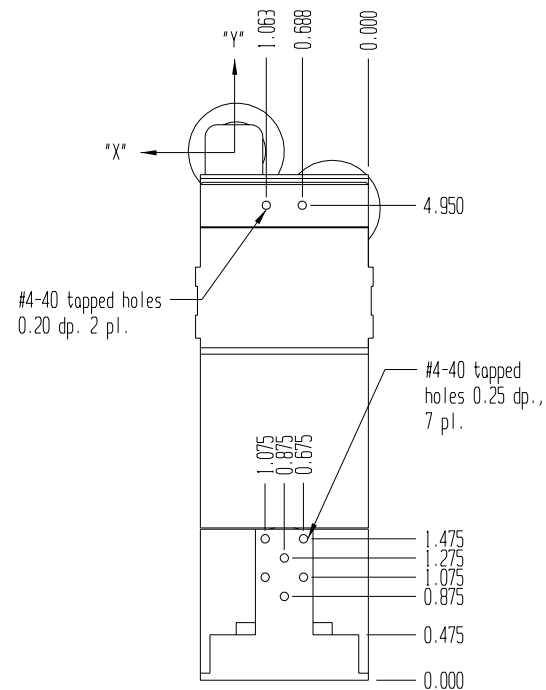
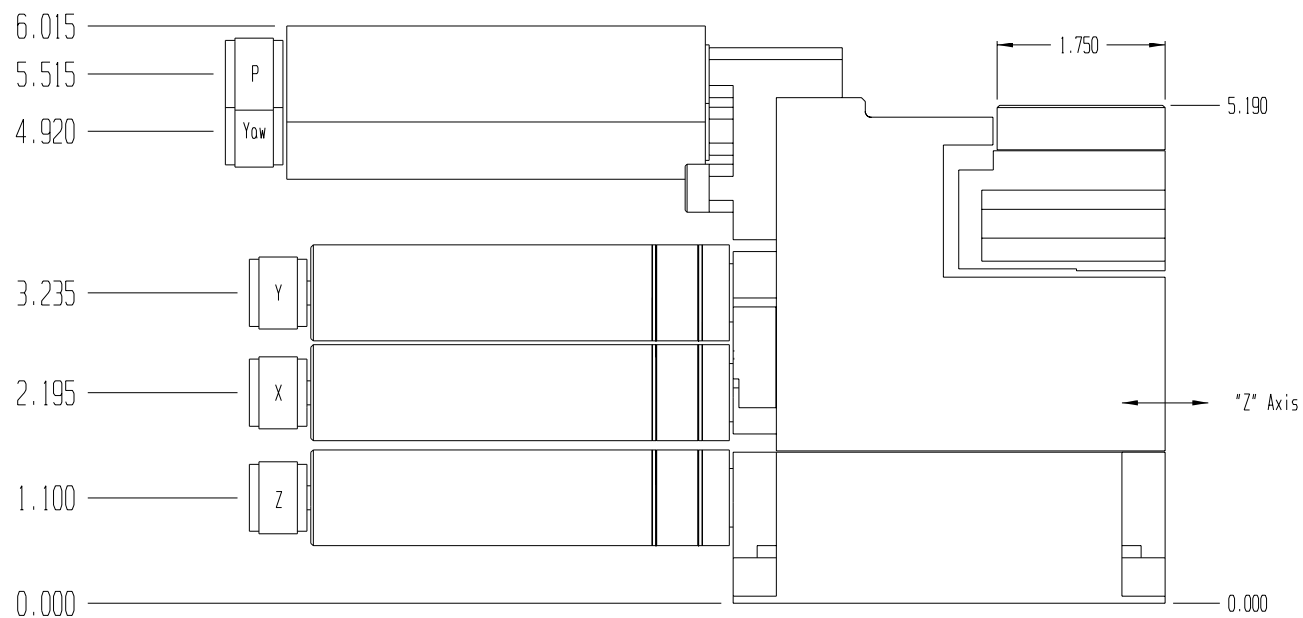

NOTE: Stage is shown in mid-position of travel  
 Z-Axis travel: +/- 0.250" (6.35mm)  
 X&Y Axis travel: +/- 0.040" (1.02mm) (coarse adjustment)  
 +/- 0.010" (250um) (fine adjustment)  
 Yaw & Pitch: +/- 1.5° each axis

LUMINOS INDUSTRIES LTD

15000 XYZYP Positioner (stepper motor) - Front & End Outline

Material:	
Finish:	Tolerance

SIZE A	VIEW	DWG NO.	15000-02	REV
SCALE 0.5	FILE	I5000.prt	SHEET 1/3	

DESCRIPTION	REV Date: Jan 09, 03	APPROVED
-------------	----------------------	----------

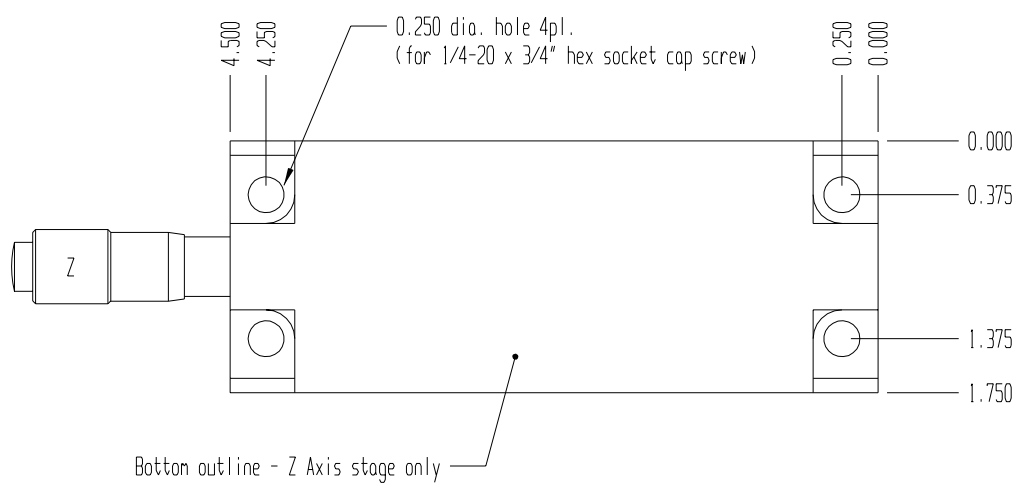
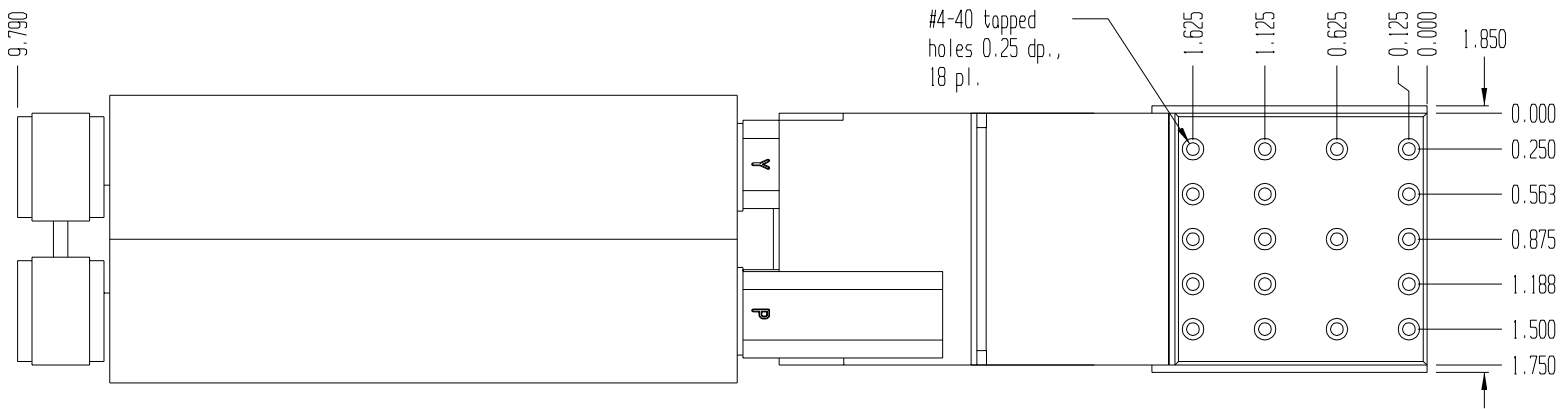

LUMINDS INDUSTRIES LTD  
 I5000 XYZYP Positioner (stepper motor)  
 Outline Top & Bottom (Z-Axis stage only)

Material:	
Finish:	Tolerance

SIZE A	VIEW	DWG NO.	I5000-02	REV A
SCALE 0.75	FILE	I5000.prt	SHEET 2/3	

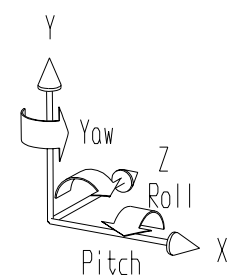
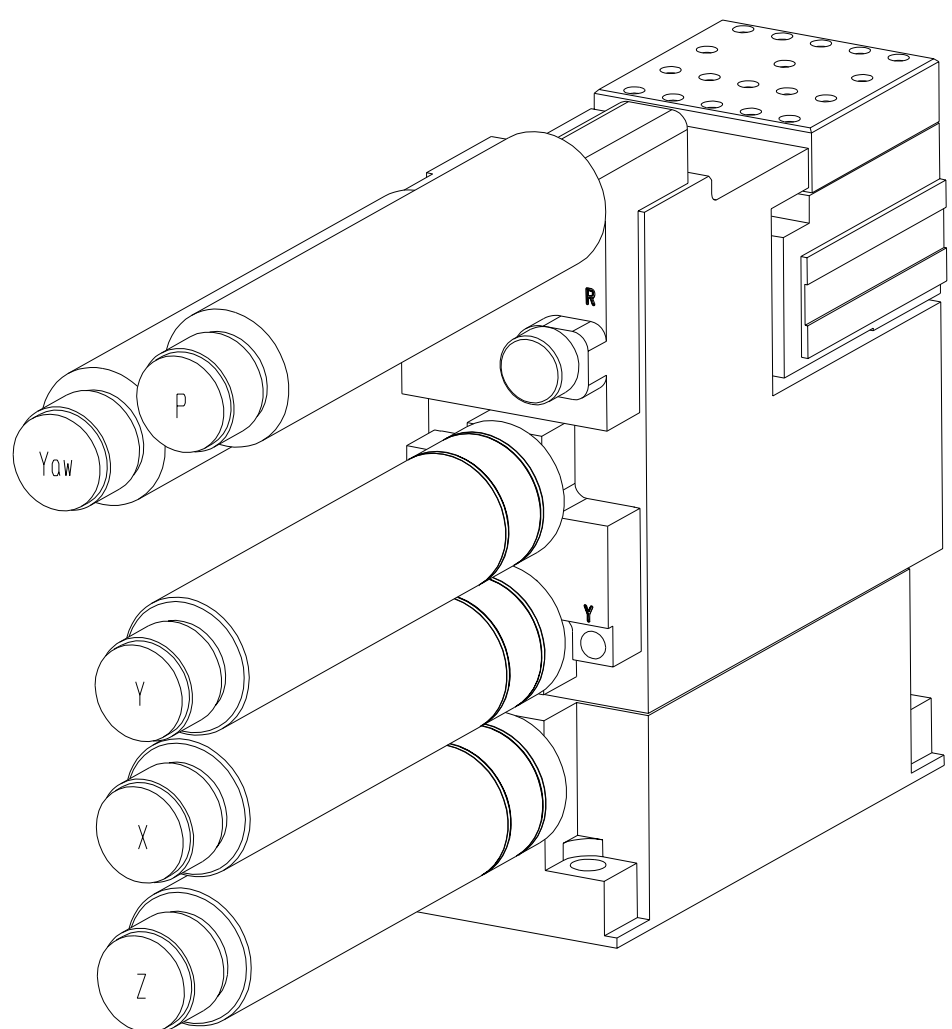

LUMINOS INDUSTRIES LTD			
I5000 XYZYP Positioner (stepper motor) - Perspective View			
SIZE A	VIEW	DWG NO. I5000-02	REV
SCALE 0.75	FILE I5000.prt	SHEET 3/3	

Material:	
Finish:	Tolerance