



**LUMINOS**  
INDUSTRIES LTD.

# ZRYP4000 4-Axis Positioner User Manual





**Table of Contents**

Introduction to the ZRYP4000 Photonics Positioner..... 1  
     Feature Summary ..... 2  
 Getting Started ..... 3  
     Reading the Micrometers ..... 3  
     Connecting an Automated Positioner ..... 4  
     Actuator Driver ..... 5  
     Mounting the Positioner..... 5  
     Mounting Devices and Accessories ..... 5  
     Accessories ..... 5  
 ZRYP4000 Specifications..... 7  
 Stepper Motor Actuators..... 8  
     Actuators with Built-In Controller (A and B Type)..... 8  
         Included Software ..... 8  
         Manual Control ..... 8  
     Actuators Without a Controller (AM and BM Type) ..... 8  
     Actuator Specifications ..... 9  
 Available Options ..... 10  
 Dimensional Drawings..... 12  
 Unpacking and Transportation..... 13  
     Locking Strip Removal ..... 13  
 Contact Us..... 14  
     Mailing Address..... 14  
     Business Hours..... 14  
     Phone Contacts..... 14  
     Email Contacts ..... 14  
 Warranty ..... 15

**Table of Figures**

Figure 1 - Connecting an Automated Positioner (A and B type actuators) ..... 4  
 Figure 2 - ZRYP4000 4-Axis Positioner ..... 6  
 Figure 3 – Mini-din Actuator Connection ..... 9  
 Figure 4 - ZRYP4000 Positioner (manual) Dimensions - Front & End ..... 12  
 Figure 5 - ZRYP4000 Positioner (manual) Dimensions - Top & Bottom..... 12  
 Figure 6 – Unpacking..... 13



## Introduction to the ZRYP4000 Photonics Positioner

Welcome to the ZRYP4000 Photonics Positioner - a positioning system so stable and easy to adjust that aligning singlemode optical fibers is as easy as tuning a radio! There is no need to let go of the micrometers during operation; the ZRYP4000 is extremely touch insensitive. With the patented ergonomic inline design, all micrometers are easily accessible on one side. Just rest your hand comfortably on the table and enjoy the ease and efficiency of quickly aligning any type of fiber.

No fiber alignment challenge is too difficult - even 1-2 micron core lensed fibers can easily be aligned. The Luminos ZRYP4000 uses a patented Ratio Drive™ for the X & Y axes resulting in less hysteresis and increased resolution.

Conventional stacked stages have separate frames with each frame simply mounted on the output of the previous stage. This results in the stiffness at the micrometer being degraded by the lack of stiffness between the mounting reference and output of each stage below it. Hand forces on the micrometer are then easily transmitted directly to the output causing the alignment to wander; thus typically resulting in an adjust-release-wait cycle by the operator.

In contrast, the ZRYP4000 consists of only two frames. The Z stage is one frame while all the other micrometers are anchored to a shared fixed frame that is attached directly to the output of the Z stage. The Z stage is exceptionally stiff and therefore is not a factor. By sharing a common rigid frame, forces exerted on the micrometers by the operator during adjustment are shunted directly to the base instead of to the output. The operator can then quickly align without letting go.

The ZRYP4000 is also vibration and temperature insensitive. Internal viscous damping eliminates many of the resonance effects typically associated with flexure stages.

Luminos stages generate extremely smooth linear motion utilizing patented flexure technology. The error motion associated with frictional ball bearings has been eliminated. Consequently, these stages move with smooth monotonic motion. The force required from an actuator in order to move a stage is also linear without the typical stiction that is found with ball or frictional type stages.

In general, single stage flexure designs are subject to arcuate motional error as each single stage moves in a physical arc. In the Luminos design, the large travel Z stage is a frictionless dual compensated flexure design wherein two precision flexure stages are made to move identically together such that the arcuate errors are eliminated. This technique offers a straightness of motion that is comparable to a precision bearing stage while affording a large travel not commonly found in flexure designs. The overall result is that the Luminos stages can be operated in even a manual mode without the operator experiencing objectionable off-axis motion.

The rotational stages are also flexure based with frictionless drive systems. All the rotational axes are coincident and pass through a focal point that is located 1" in front of the stage and ½ inch above the work plate. This allows for up to 4 – 6 Axis stages to be arranged in a cluster around a small sample if desired. The Pitch and Yaw flexure stages

have been carefully designed as “dual compensated flexure stages” identical in concept to the Z Axis stage. This allows an operator to pivot in virtual space without any significant off-axis arc error motion. Believe it or not, two aligned tapered optical single mode fibers with a mode field diameter of even 2 microns can be rotated throughout pitch and yaw while maintaining the optical signal. The roll stage is a frictionless drive single stage design. In a typical alignment of a fiber array, the bulk of any Roll adjustment is carried out in a far-field alignment state in order to align the fibers at either end of a fiber array. Subsequent fine rotational adjustments are then very minor and off-axis error motion is negligible. The precision and ease of use of this stage truly cannot be appreciated without having used it. Luminos also offers full automation solutions based on the ZRYP4000 positioning platform that are truly unique. A complete automated solution including controllers can be held in your hand.

### ***Feature Summary***

---

- Patented Inline actuators provide ease of access and multiple unit workstations.
- Small footprint allows multiple unit workstations (Fig 2).
- Onboard controller for actuators avoids high cost of separate motion controllers.
- Damped exterior shell design provides superior vibration and touch insensitivity.
- Lightweight aluminum construction allows system to be moved easily by other motion equipment.
- High mechanical stiffness affords rugged and stable base system.
- Patented linear dual flexure Z offers frictionless repeatable straight travel.
- Dual flexure Yaw and Pitch stages provide extreme resolution without arc error.

With positioning this easy... the possibilities are endless.

## Getting Started

**Before unpacking the positioner, please read** Unpacking and Transportation **on page 13.**

### *Reading the Micrometers*

The following table gives the conversion necessary to interpret the numbers read from the micrometer.

Axis	Smallest Division (A)		1 Rotation (B)	
<b>Pitch</b>	30	arc seconds	15	arc minutes
<b>Yaw</b>	30	arc seconds	15	arc minutes
<b>Roll</b>	10	arc seconds	10	arc minutes
<b>Z</b>	0.001	inches	0.025	inches

Each line on the shaft of the micrometer corresponds to one rotation. The “smallest division” refers to the divisions on the knob of the micrometer. Clockwise rotation of each micrometer causes movement in a positive direction as shown in Figure 2 (pg. 6).

To calculate the position, count the number of divisions on the shaft between the current position and zero. Multiply that number by the movement per rotation (B) given in the table above. Then, count the number divisions on the knob from zero, multiply that number by the movement per smallest division (A in the table above). Add the two products calculated to give the position. The formula is summarized as:

$$\text{Position} = (\text{Shaft\_Divisions} \times \text{B}) + (\text{Knob\_Divisions} \times \text{A})$$

**Note:** If the coarse adjustment of the X or Y axis is moved, the position read from the micrometer of that axis will not be the same physical position as before moving the coarse adjustment.

## ***Connecting an Automated Positioner***

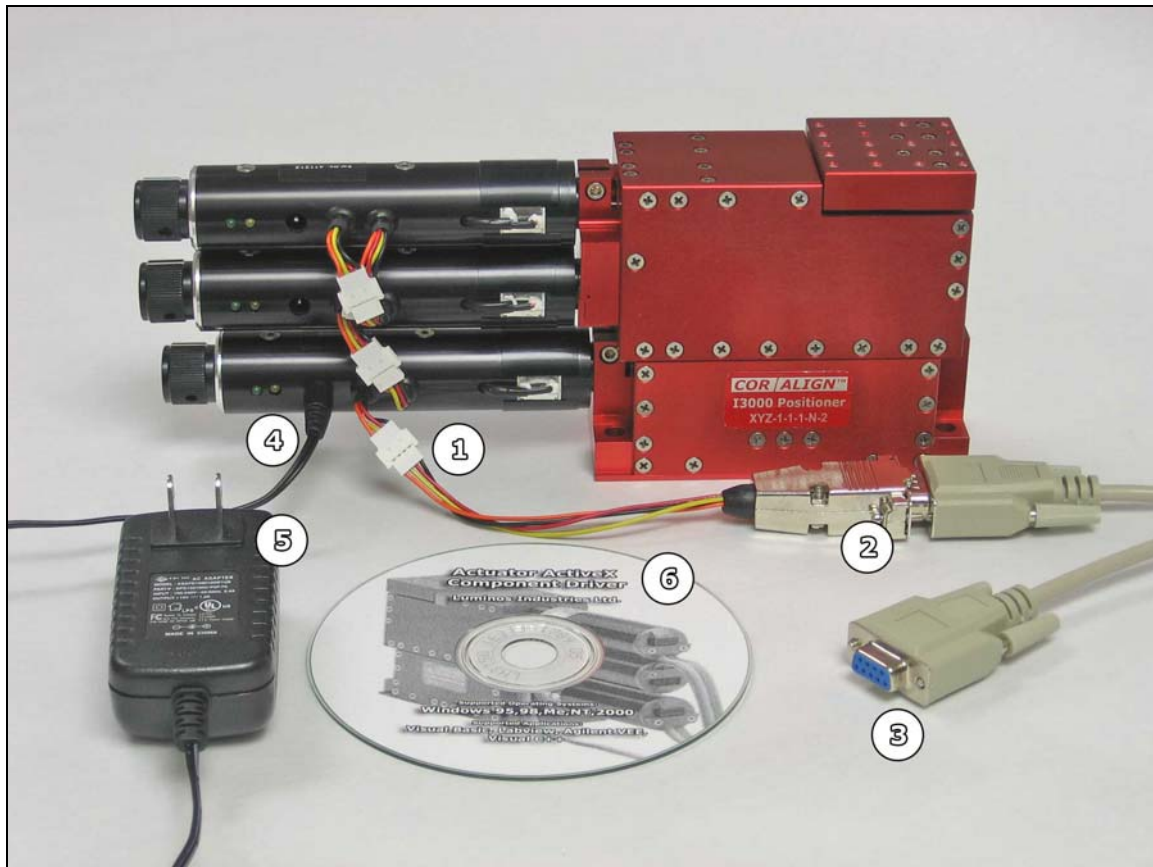

**Figure 1 - Connecting an Automated Positioner (A and B type actuators)**

To connect your positioner, use the following steps:

1. Connect the 9-pin adapter with the matching white connector to white connector on the bottom actuator closest to the manual knob. On any positioner with more than one axis, this will be the only white connector available on the bottom actuator. (Do not disconnect actuators that are already connected).
2. Connect the other end of the adapter (a female DB9 9 pin connector) to the 9-pin serial extension cable.
3. The end of the cable is a standard 9-pin female serial connection and should connect to one of the serial ports on the back of the computer (or to a Serial-USB adapter to utilize a USB port instead).
4. Connect the 12-16V DC (minimum 800mA) power adapter to the bottom actuator. The rest of the actuators are power through the daisy chain.
5. Plug the power adapter into a standard receptacle.
6. Install the software driver using the CD provided. Help for using the driver is included as part of the installation.



## ***Actuator Driver***

---

The documentation for actuator driver is included in the accompanying Driver CD (if applicable). This format allows easy access from within most software development environments.

## ***Mounting the Positioner***

---

The ZRYP4000 mounts using ¼-20 screws on 1 inch and 4 inch centers (see Figure 5 - ZRYP4000 Positioner (manual) Dimensions - Top & Bottom, pg 12)

## ***Mounting Devices and Accessories***

---

The device mounting plate (the square plate at the top of the positioner) is where devices and accessories are mounted. For dimensions, see Figure 5 on page 12. As shown in Figure 2 (pg. 6), the center of rotation for all axes is 1 inch out and ½ inch up from the end of the device mounting plate. To avoid having to adjust the X, Y and Z axes when rotating the device, the device alignment point should be as close as possible to the rotation center.

## ***Accessories***

---

There are many accessories available including a contact sensing system for sensing very small forces in the Z (focal) direction. Contact us if there is an accessory you require.

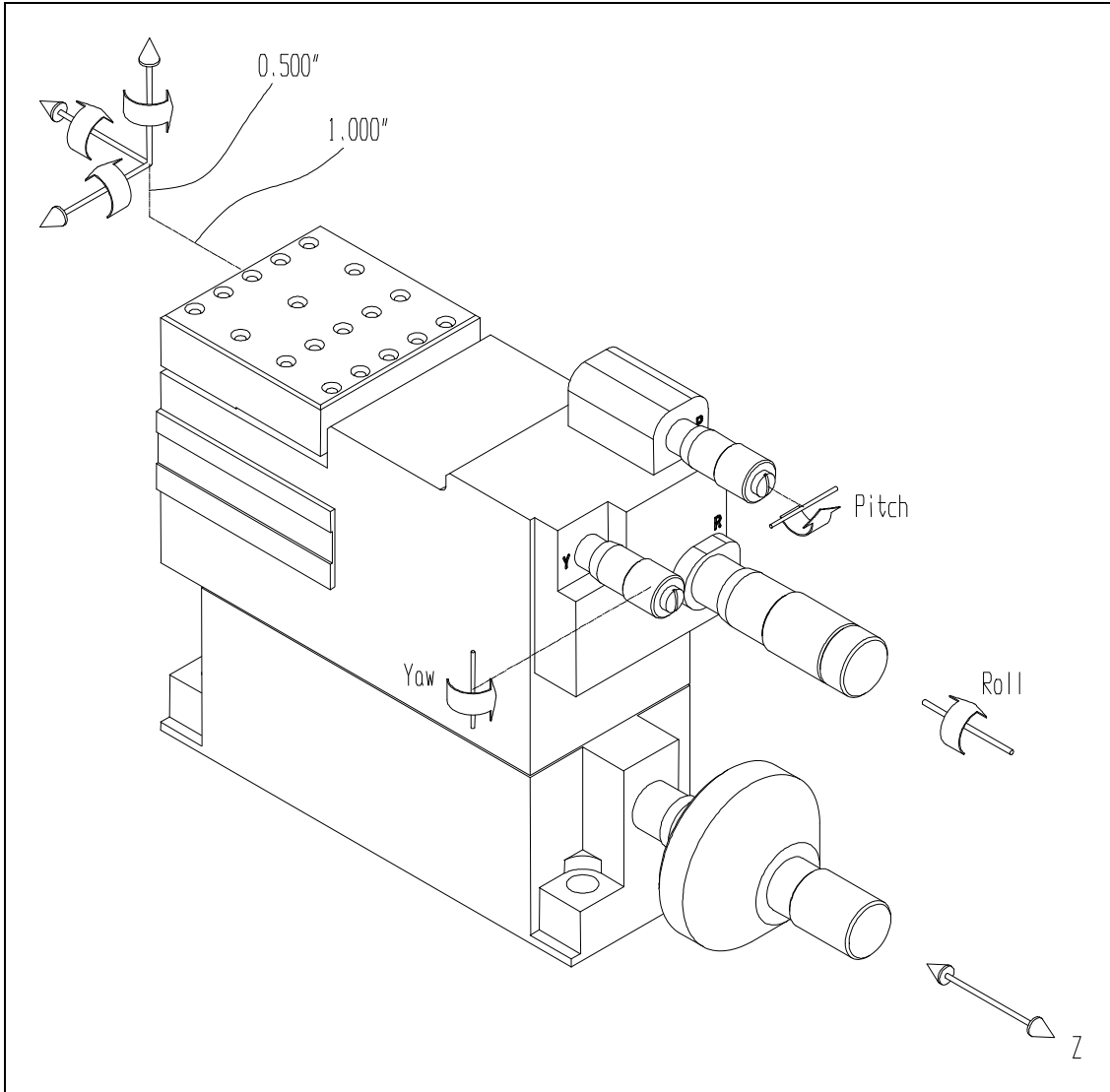

Figure 2 - ZRYP4000 4-Axis Positioner

## ZRYP4000 Specifications

Travel			
<i>Axis</i>	<i>Actuator<sup>1</sup></i>	<i>Coarse</i>	<i>Total</i>
Z – focus	12.7mm (0.5")	N/A	12.7mm (0.500")
Roll	3 degrees	N/A	3 degrees
Yaw	3 degrees	N/A	3 degrees
Pitch	3 degrees	N/A	3 degrees
Setability <sup>2</sup> (Micrometer)			
<i>Axis</i>	<i>Resolution</i>	<i>Movement /Division</i>	
Z	0.25 micron (10μ-inch)	0.001"	
Roll	0.1 arc sec	10 arc sec	
Yaw	0.2 arc sec	30 arc sec	
Pitch	0.2 arc sec	30 arc sec	
Resolution (Stepper Motor)			
<i>Axis</i>	<i>Resolution</i>	<i>Total Steps</i>	
Z	100nm (4μ-inch)	128 000	
Roll	0.1 arc sec	101 206	
Yaw	0.2 arc sec	60 416	
Pitch	0.2 arc sec	60 416	
Stage Configuration & Arc Error Motion			
<i>Axis</i>	<i>Flexure Type</i>	<i>Arc Error</i>	
Z	Dual	None - True Linear Motion	
Roll	Single	Max 35μm	
Yaw	Dual	None	
Pitch	Dual	None	
Linear Stiffness			
<i>Along Axis</i>	<i>Stiffness</i>	<i>Comments</i>	
Z	230 kN/m	measured at the rotation center	
Y	110 kN/m	measured at the rotation center	
X	50 kN/m	measured at the rotation center	
Torsional Stiffness			
<i>About Axis</i>	<i>Stiffness</i>	<i>Comments</i>	
Z – roll	75 Nm/rad	measured at the rotation center	
Y – yaw	110 Nm/rad	measured at the rotation center	
X – pitch	140 Nm/rad	measured at the rotation center	
Maximum Load			
<i>Static Load</i>	<i>Transient Load</i>	<i>Comments</i>	
2.2 lbs (1kg)	10 lbs (4.5kg)	stage must be protected from shock loading during transport and usage	

Physical Properties		
<i>Characteristic</i>	<i>Specifications</i>	<i>Comments</i>
Construction	Aluminum	6061 & 7075 - T6 anodized
Weight	1.0kg	Approximate
Body Dimensions	4.50" x 1.75" x 3.94"	L x W x H excluding micrometers
Mounting Height	3.94"	Base to top of mounting plate
Mounting Configuration	0.26" diameter holes	1.00" x 4.00" <sup>3</sup> centers
Concurrent Rotation Center	1/2"	Above top of mounting plate
	1"	Out from end of mounting plate

<sup>1</sup> 'Actuator' refers to a micrometer or stepper motor.

<sup>2</sup> Operator dependent

<sup>3</sup> Compatible with 1.00" grid optical tables, units mount on 2" intervals with 0.25" allowance for routing of cables etc.

## Stepper Motor Actuators

### ***Actuators with Built-In Controller (A and B Type)***

The A and B type actuators do not require an external stepper motor driver - these slim actuators actually contain an onboard RS-232 controller which interfaces directly with any standard PC serial port (or USB port with a low cost adapter). Each Positioner is shipped with a 15 Volt, 1 Amp DC Voltage adapter, a 4-pin Molex to 9-pin serial adapter, and a 2m 9-pin extension.

### **Included Software**

An included ActiveX/COM™ software component makes it easy to get up and running quickly in any windows based development environment (including Visual Basic, Labview, and C++, or any of the .NET languages).

### **Manual Control**

A convenient knob at the end of the unit permits manual control. During a manual move the actuator constantly updates the connected computer with its position. If accidental movement is a concern, the manual control can be enabled and disabled via computer control.

### ***Actuators Without a Controller (AM and BM Type)***

The AM and BM type actuators are equivalent to the A and B type actuators without controllers. They are provided with direct connections to the two phases of the bipolar stepper motor (4 wires) and a Hall Effect limit sensor (3 wires) through a male 8-pin mini-din connector.

This option allows those with an existing system for driving stepper motors to avoid changing over to RS-232 based control. However, for new applications, this option is not recommended due to the high cost of separate controllers.

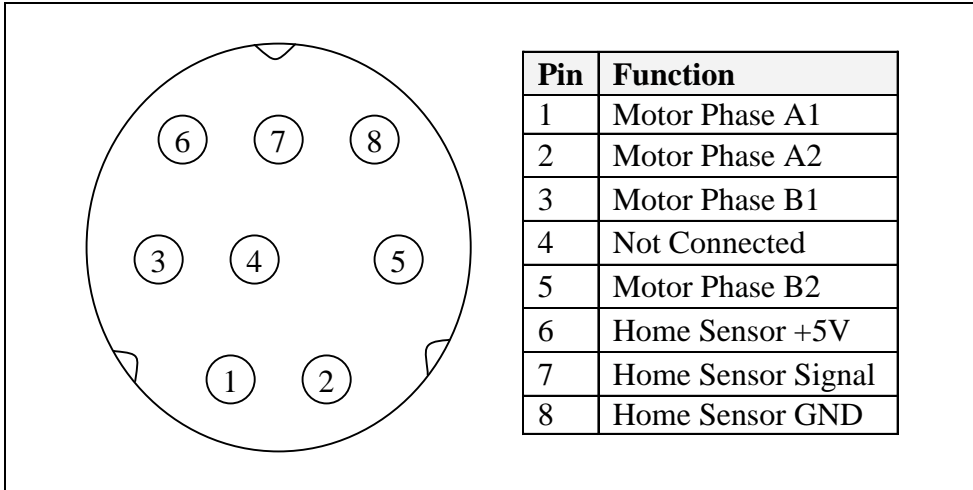

Figure 3 – Mini-din Actuator Connection

### Actuator Specifications

Description	Actuator Type			
	A	AM	B	BM
Motor Type	Bipolar Stepper			
Built-in Controller	Yes	No	Yes	No
Steps Per Revolution	48			
Motion Per Step	6.35 $\mu\text{m}$		12.7 $\mu\text{m}$	
Power Per Phase	1.7W			
Resistance Per Phase	84 ohms		14.7 ohms	
Current per Phase	140 mA		340 mA	
Inductance per Phase	55 mH		8.5 mH	
Accuracy	< 12 $\mu\text{m}$		< 16 $\mu\text{m}$	
Backlash	< 4 $\mu\text{m}$		< 8 $\mu\text{m}$	
Repeatability	< 0.4 $\mu\text{m}$		< 0.8 $\mu\text{m}$	
Power Supply	12V-16V DC unregulated 2.1mm center positive plug (A and B type only)			
Current Draw	Idle: 100 mA Moving: 320 mA			

Table 1 - Actuator Specifications

## Available Options

### Z Actuator

Manual Imperial Micrometer (default)

*A micrometer where the smallest division is 0.001 inches  
(0.025" per revolution)*

Differential Micrometer (Imperial)

*A double threaded micrometer for increased resolution where the smallest  
division is 0.00002 inches.*

Stepper, Fine Travel, 0.1µm microstep, RS-232 Onboard Controller

Stepper, Long Life, 0.2µm microstep, RS-232 Onboard Controller

Stepper, Fine Travel, 6.4µm fullstep, Direct Mini-DIN 8

Stepper, Long Life, 12.8µm fullstep, Direct Mini-DIN 8

### Roll Actuator

Manual Micrometer (default)

*A micrometer where the smallest division is 10 arc sec  
(10 arc min per revolution)*

Stepper, Fine Travel, 0.1µm microstep, RS-232 Onboard Controller

Stepper, Long Life, 0.2µm microstep, RS-232 Onboard Controller

Stepper, Fine Travel, 6.4µm fullstep, Direct Mini-DIN 8

Stepper, Long Life, 12.8µm fullstep, Direct Mini-DIN 8

### Yaw Actuator

Manual Micrometer (default)

*A micrometer where the smallest division is 30 arc sec  
(15 arc min per revolution)*

Stepper, Fine Travel, 0.1µm microstep, RS-232 Onboard Controller

Stepper, Long Life, 0.2µm microstep, RS-232 Onboard Controller

Stepper, Fine Travel, 6.4µm fullstep, Direct Mini-DIN 8

Stepper, Long Life, 12.8µm fullstep, Direct Mini-DIN 8

### Pitch Actuator

Manual Micrometer (default)

*A micrometer where the smallest division is 30 arc sec  
(15 arc min per revolution)*

Stepper, Fine Travel, 0.1µm microstep, RS-232 Onboard Controller

Stepper, Long Life, 0.2µm microstep, RS-232 Onboard Controller

Stepper, Fine Travel, 6.4 $\mu$ m fullstep, Direct Mini-DIN 8

Stepper, Long Life, 12.8 $\mu$ m fullstep, Direct Mini-DIN 8

## **Mounting Axis**

### Horizontal (default)

*The positioner is set up to be balanced in the horizontal and upright position.*

### Vertical

*The positioner is set up to be balanced with the micrometers pointing up. This configuration requires more preload on the z-axis.*

## Dimensional Drawings

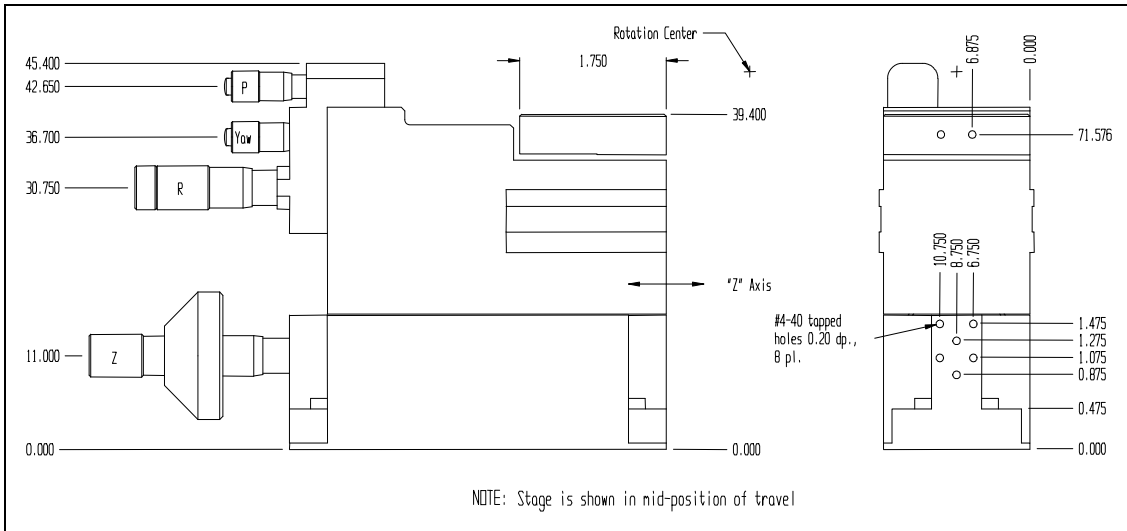

**Figure 4 - ZRYP4000 Positioner (manual) Dimensions - Front & End**

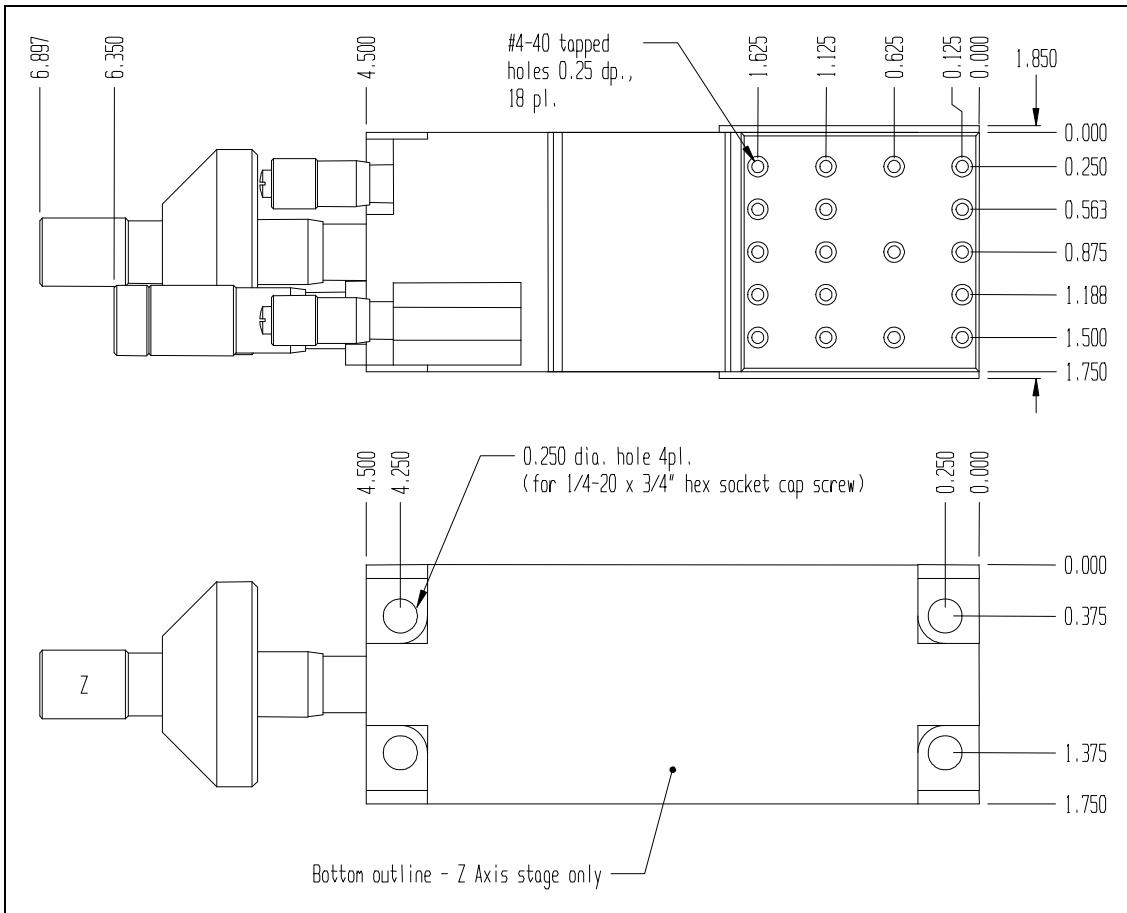

**Figure 5 - ZRYP4000 Positioner (manual) Dimensions - Top & Bottom**



## Unpacking and Transportation

**Do not discard packaging! The warranty is void if a Positioner is not shipped in the original packaging.**

### *Locking Strip Removal*

To prevent damage to the Z axis linkage during transportation a plastic locking strip is inserted between the upper and lower part of the unit (see Figure 6, below). To remove the locking strip, apply hand force to the upper portion of the unit (Z axis direction), remove locking strip and carefully allow the unit to return to its pre-loaded position. This procedure is applicable to all positioner types.

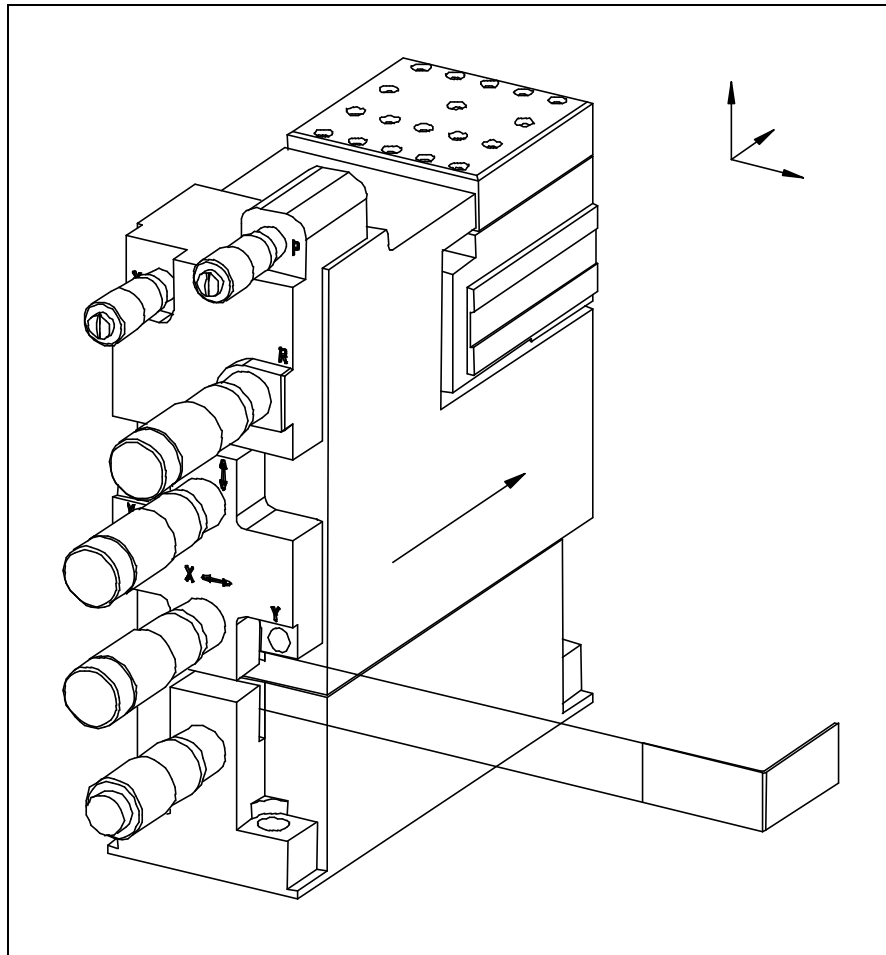

Figure 6 – Unpacking

## Contact Us

Thank you for purchasing a Luminos product. We want to ensure your experience is a positive one. If you have any questions, concerns, or comments do not hesitate to contact us.

### ***Mailing Address***

---

Luminos Industries Ltd.  
8-58 Antares Drive  
Ottawa, Ontario  
K2E 7W6 - Canada

### ***Business Hours***

---

Monday to Friday: 8:00am-4:30pm EST

### ***Phone Contacts***

---

Telephone: 1 (613) 225-7661  
Fax: 1 (613) 225-3391

### ***Email Contacts***

---

Sales: [sales@luminosindustries.com](mailto:sales@luminosindustries.com)  
General Inquiry: [info@luminosindustries.com](mailto:info@luminosindustries.com)  
Support: [support@luminosindustries.com](mailto:support@luminosindustries.com)

## Warranty

All items manufactured by Luminos Industries Ltd. are warranted to meet Luminos Industries' published specifications and to be free of defects in materials and workmanship as defined in the specifications for 90 days after delivery. Luminos Industries Ltd. will, at its own option, repair or replace without charge any listed item discovered to be defective.

Luminos Industries Ltd. will not be held liable for any loss whatsoever beyond the purchase price paid by the buyer for the goods to which claim is made. Luminos Industries does not give implied warranties of merchantability, fitness for a particular purpose, or of any other nature in connection with the sale of any Luminos Industries Ltd. products.

Products not returned in original packaging will void this warranty.

This warranty does not extend to cover damage resulting from alteration, misuse, negligence, abuse, normal wear and tear, or accident.





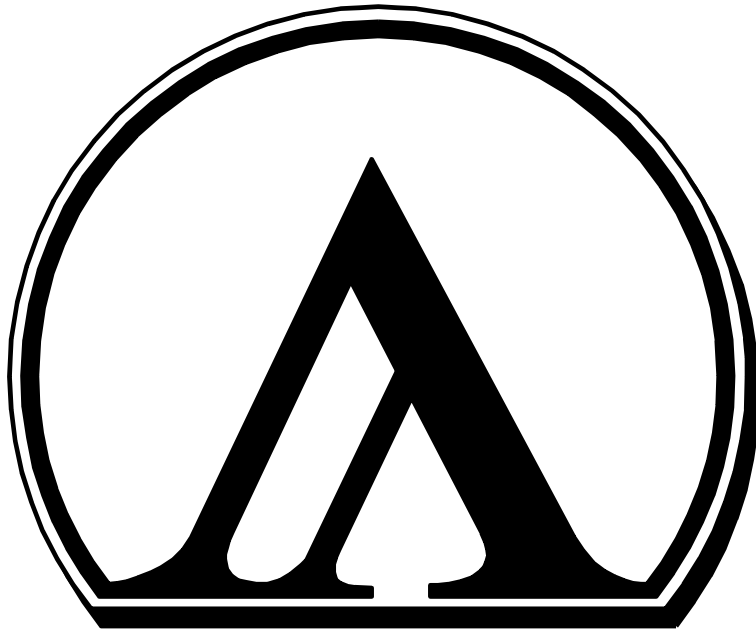

**LUMINOS**  
**INDUSTRIES LTD.**

**58 Antares Drive  
Ottawa, Ontario  
Canada  
K2E 7W6**

**613 225 7661 – tel  
613 225 3391 – fax**

**[www.luminosindustries.com](http://www.luminosindustries.com)  
[info@luminosindustries.com](mailto:info@luminosindustries.com)**