



SEIKOH GIKEN

SFPS-V2

Automated Polishing System For Multi-Fiber



■ Features

➤ 1. Automatization of polishing process

Except for the connector setting and inspection, SFPS-V2 automates all the conventional polishing and operator works

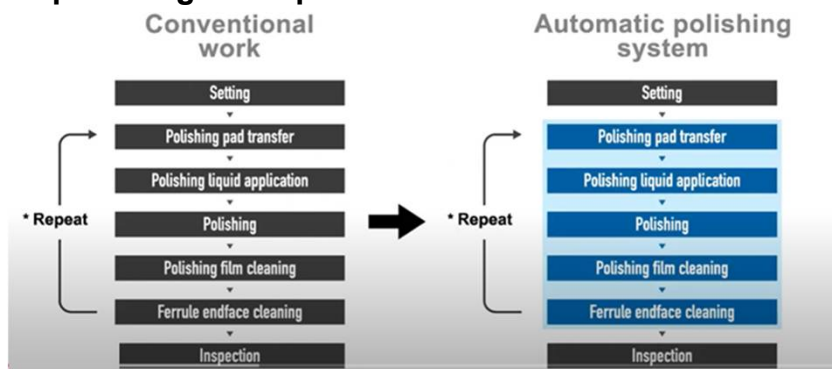

➤ 2. Use of polishing machine for factory automation

The dedicated polisher SFP-560A3C-FA offers three key features essential for FA

- 1) Auto clamping
- 2) Network connection
- 3) Turntable origin return

➤ 3. Water-wash system dedicated to Multi-Fiber polishing

Effectively removes polishing residues, preparing the holder for ultrasonic cleaning.

*** For multi-fiber polishing, it is necessary to use a polishing holder compatible with the Water-Wash System.**

中国大陆代理商

深圳市谱兆通讯设备有限公司

Tel:+86-755-8665-5448;+86-755-8665-5579; Email:info@pztest.com Website:www.pztest.com

Seikoh Giken reserves the right to improve, enhance and modify features and specifications of Seikoh Giken products without prior notifications

■ Features

➤ 4. Designed for large-diameter cables

A standout feature of the SFPS-V2—also available in the SFPS-V1—delivered through the polisher’s four-corner auto clamp, advanced DPC technology, and the optimized cable traveling distance provided by the automated machine.

(DPC: Dynamic Pressure Control)



➤ 5. Small-foot print

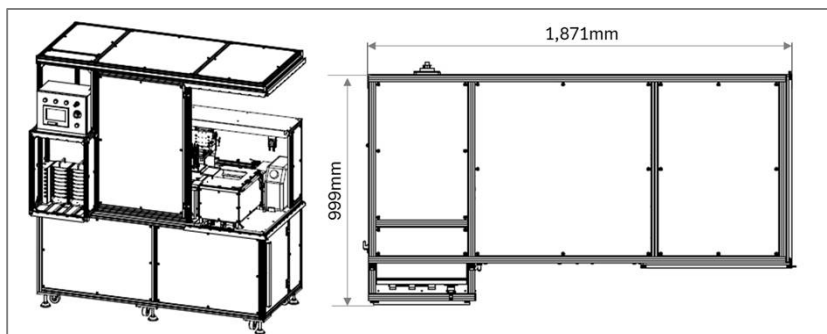

■ Advantages

Easy to handle
small-lot
multi-variety
production

Reduction of
worker man-hours
(down 50%)

Reduction of
operator dependency

■ Specification

Item	Performance
Application	Multi Fiber ferrules and Single fiber connectors
Consumables	Loading tray style pad stocker & Replaceable during operation
Handling	Deliver consumables automatically with three-jaws chuck
Liquid	Controlled amount is applied before start of each step
Wiping	Clean surface of film with cleaning wipe after each polishing step
Cleaning system	Water-wash + Ultrasonic bath + Air blow after each polishing step
Water wash	Draining to the reserve tank
Sonic bath	Water circulation system through two types of filters
Power sources	Compressed air and Electricity (200V / 220V / 240V)
Safety	Physical protection cover and light curtains and conforms the CE
Tact time	Approx. 15 min for 24-36 axis multi-fiber ferrule polishing